

### THE SAFEST AND EASIEST TO OPERATE HYDRAULIC EDGE-OF-DOCK LEVELER



Nearly 50 years ago, DLM® invented the edge-of-dock leveler and quickly set the standard for the industry. Today, the DLM HED Series sets a new standard. It is the absolute state-of-the-art in hydraulically operated edge-of-dock levelers. The DLM HED is yet another reason why there are more DLM edge-of-dock levelers in service than those of all other companies combined.

#### **DLM® Overview...**

- DLM Pioneered the Edge-Of-Dock Industry by Inventing the EOD Leveler In 1962
- On-site Engineering & Customer Support
- Superior Structural Construction
- Privately Held – “Customer Focused” Enterprise
- Extensive Application Experience
- Fully Integrated Manufacturing Facility
- National Network of Knowledgeable Sales and Service Representatives
- Accepted Nationally by Fortune 500 Companies

#### **SAFE AND EASY**

The “HED” Series is a full control, state of the art hydraulically-operated edge-of-dock leveler. It is controlled remotely from a wall mounted control panel. The platform is raised when the raise push button is depressed and held. When the lip extends the button is released allowing the extended lip and platform to lower onto the trailer. The leveler can be stored by depressing the raise button until the lip clears the trailer bed then releasing the button to store the unit. Alternatively, the leveler will store automatically once the trailer has departed.

The DLM “HED” mounts to the dock face and provides a recommended working range of  $\pm 3$ ” and a maximum operating range of  $\pm 5$ ” above and below dock level. Deck and lip are constructed with high-strength steel safety tread plate (minimum yield of 55,000 psi). Lip hinge tubes include grease fittings for ease of maintenance and longer life

The “HED” Series EOD is a quality-made fully hydraulic edge-of-dock leveler that will provide years of easy, dependable operation.

# Edge-Of-Dock

## "HED" Series Hydraulic Edge Of Dock



DLM's continuing commitment, is to design and build the very best dock levelers our industry has to offer. A strong customer focus has facilitated the inclusion of important user features into every "HED" Series leveler - important features like:

### Structurally Superior

- Milled lip edge for smooth tire rollover.
- Leveler lip and deck are constructed with high-strength 55,000 psi. min. yield, steel safety treadplate.
- Two steel gussets for added strength and extended life.
- Full width distribution bar for extra durability.
- Deck construction is capacity dependent to insure your loading bridge matches the demands of the facility.

### Bumper Options

- Properly designed dock bumpers helps protect the deck plate and building from the approaching truck.
- Constructed of formed steel and incorporate a full height internal gusset for extra support.
- Feature 4" thick Tuf-Cord rubber bumper.
- Every leveler is shipped standard with 12" x 13" heavy duty bumper blocks. (shown below in foreground)
- Optional sliding bumpers that rise as the truck is being unloaded - thus reducing wear and tear. (shown to right in background)
- Optional 18" tall steel faced or laminated bumpers.



### HED Series Standard Features Include ...

- NEMA 4 push button control panel
- 115V 1-phase motor
- Cold rolled steel hinge pins for added strength & long life
- Milled lip edge for smooth tire rollover
- Grease fittings throughout
- High strength steel safety tread plate
- Fully hydraulic lip & deck cylinders
- 66", 72", 78", and 84" deck width
- 104", 110", 116", and 12" total widths
- Comparable industry rating (CIR) capacities 20,000 lbs, 25,000 lbs, 30,000 lbs, and 35,000 lbs
- Secondary gussets for added strength & extended life
- Heavy duty bumper block assemblies with Tuf-Cord rubber bumpers 4"x12"x13"
- Bumper projection 18"

### Simple Push Button Control

- Non-metallic Nema 4 single push button control.
- Control components are UL listed or recognized.
- Overload protection for motor is standard.
- 115V 1-phase motor



### Installation Method

- For new construction, a flush or recessed 8" - 12" embed channel (shown) is strongly recommended. Unit is then welded to the embed channel in the foundation wall. For existing docks without preferred embed channel, optional ramp approach plates or formed angles are available to maximize the strength of installation.

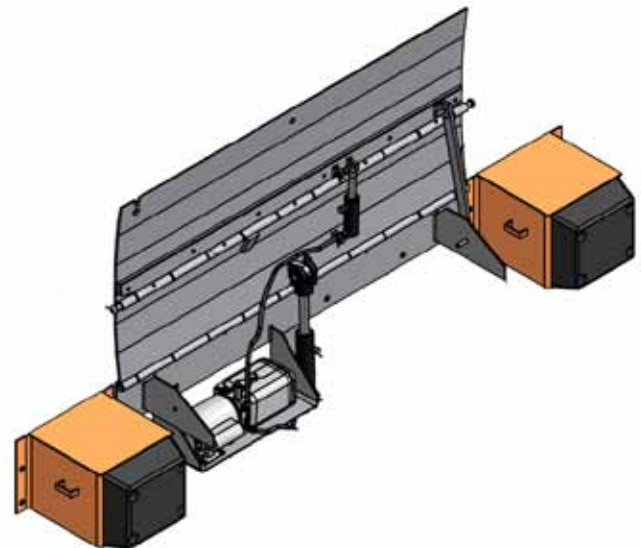
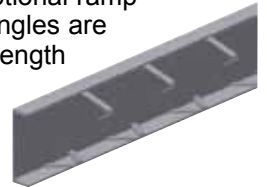

**Designed, Engineered & Manufactured in the U.S.A.**

**Distributed By:**



DLM • Division of Systems, Inc.  
Germantown, WI 53022  
800.643.5424 • fax: 262.255.4199  
www.DLMinc.net • www.DockSystemsInc.com