

**THE SAFEST AND EASIEST TO OPERATE MECHANICAL
EDGE-OF-DOCK LEVELER**



Nearly 50 years ago, DLM® invented the edge-of-dock leveler and quickly set the standard for the industry. Today, the DLM NEVERLIFT® sets a new standard. It is the absolute state-of-the-art in lever-operated edge-of-dock levelers. The DLM NEVERLIFT is yet another reason why there are more DLM edge-of-dock levelers in service than those of all other companies combined.

DLM® Overview...

- DLM Pioneered the Edge-Of-Dock Industry by Inventing the EOD Leveler In 1962
- On-site Engineering & Customer Support
- Superior Structural Construction
- Privately Held – “Customer Focused” Enterprise
- Extensive Application Experience
- Fully Integrated Manufacturing Facility
- National Network of Knowledgeable Sales and Service Representatives
- Accepted Nationally by Fortune 500 Companies

SAFE AND EASY

The “NL” Series edge-of-dock leveler is the state of the art in lever-operated dock levelers. Simply move the lifting lever 50° towards the operator, then push the lever forward to its original vertical position.

That is all there is to it. The push/pull motion is short and easy - and you stand upright and ergonomically correct to do so. There’s never any lifting and never any leaning over the dock edge.

The DLM NEVERLIFT® mounts to the dock face and provides a recommended working range of +/-3” and a maximum operating range of +/-5” above and below dock level. Deck and lip are constructed with high-strength steel safety tread plate (minimum yield of 55,000 psi). Lip hinge tubes include grease fittings for ease of maintenance and longer life.

The “NL” Series EOD is a quality made edge-of-dock leveler that will provide years of easy, dependable operation.

Edge-Of-Dock

NEVERLIFT "NL" Series Mechanical Edge Of Dock



DLM's continuing commitment, is to design and build the very best dock levelers our industry has to offer. A strong customer focus has facilitated the inclusion of important user features into every "NL" Series leveler - important features like:

Structurally Superior

- Milled lip edge for smooth tire rollover.
- Leveler lip and deck are constructed with high-strength 55,000 psi min. yield, steel safety treadplate.
- Four steel gussets for added strength and extended life.
- Full width distribution bar for extra durability.
- Deck construction is capacity dependent to insure your loading bridge matches the demands of the facility.

Bumper Options

- Properly designed dock bumpers helps protect the deck plate and building from the approaching truck.
- Constructed of formed steel and incorporate a full height internal gusset for extra support.
- Feature 4" thick Tuf-Cord rubber bumper.
- Every leveler is shipped standard with 12" x 13" heavy duty bumper blocks. (shown below in foreground)
- Optional sliding bumpers that rise as the truck is being unloaded - thus reducing wear and tear. (shown to right in background)
- Optional 18" tall steel faced or laminated bumpers.



NL Series Standard Features Include ...

- | | |
|---|--|
| • Dual-extension spring lift mechanism | • 66", 72", 78" and 84" deck widths |
| • Heavy-duty self-storing steel lever with EZ grip handle | • 104", 110" 116" and 122" total widths |
| • Heavy-duty self-storing steel lever | • Comparable industry rating (CIR) capacities 20,000 lbs, 25,000 lbs, 30,000 lbs, and 35,000 lbs |
| • Cold rolled steel hinge pins for added strength & long life | • Secondary gussets for added strength & extended life |
| • Milled lip edge for smooth tire rollover | • Heavy duty bumper block assembles with Tuf-Cord rubber bumpers 4"x12"x13" |
| • Grease fittings throughout | • Bumper projection 15" |
| • High strength steel safety tread plate | |
| • Full width distribution bar for extra durability | |

Operation Of Unit

- First, place the handle in the side mounted receiver and pull back on the lever approximately 50°.
- Next push the lever toward its original position using the positioning rivet.
- Leveler is deployed.
- To store simply repeat the process until the lip clears the trailer and allow the unit to collapse into its stored position or when truck departs the leveler will automatically return to the stored position.



Installation Method

- For new construction, a flush or recessed 8" - 12" embed channel (shown) is strongly recommended. Unit is then welded to the embed channel in the foundation wall. For existing docks without preferred embed channel, optional ramp approach plates or formed angles are available to maximize the strength of installation.

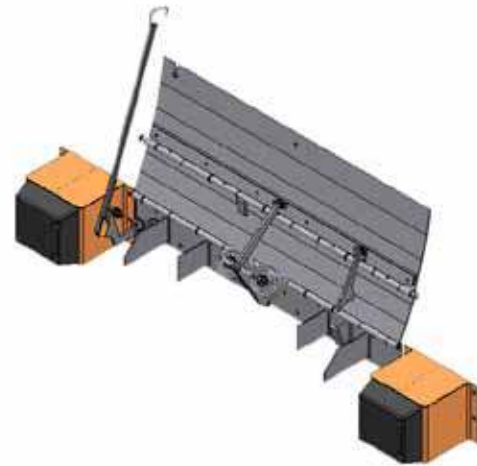
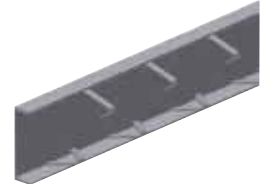

Designed, Engineered & Manufactured in the U.S.A.

Distributed By:



A Division of Systems, Inc.



DLM • Division of Systems, Inc.
Germantown, WI 53022
800.643.5424 • fax: 262.255.4199
www.DLMinc.net • www.DockSystemsInc.com